



Welcome to the  
**1st IEEE LCN Workshop on Maritime  
Communication and Security**

Jan Bauer

Fraunhofer FKIE  
Germany

Ulku Clark

University of North Carolina  
USA

Gary C. Kessler

Gary Kessler Associates  
USA

5 October 2023

# Maritime Cybersecurity Challenges

0) The word *cybersecurity*

1) Vulnerability of navigation systems

2) Autonomy and Industry 4.0

3-?) Workforce development

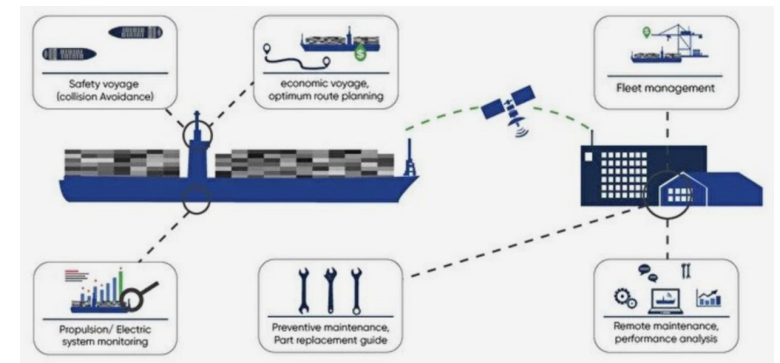
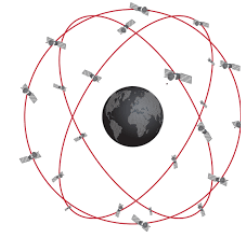

# Authors by Country and Region

## Submissions

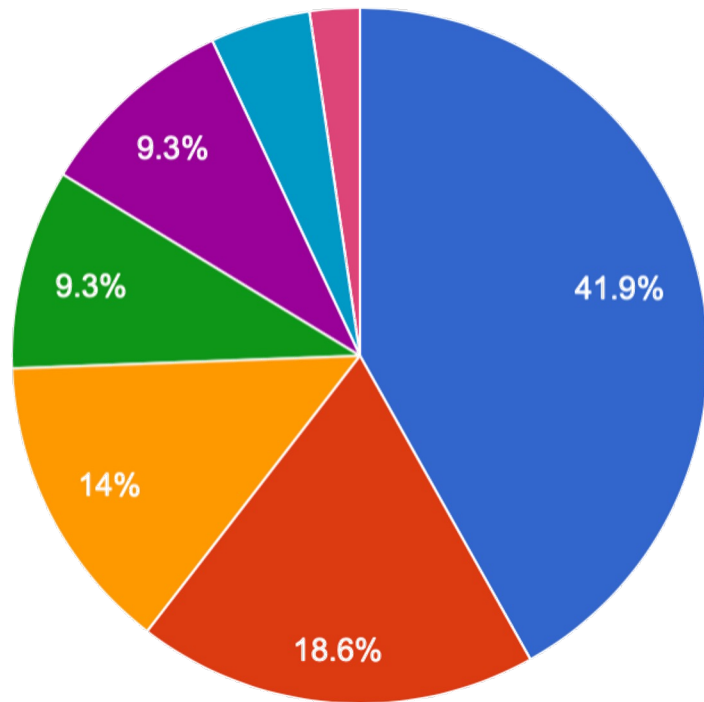

## Accepted papers

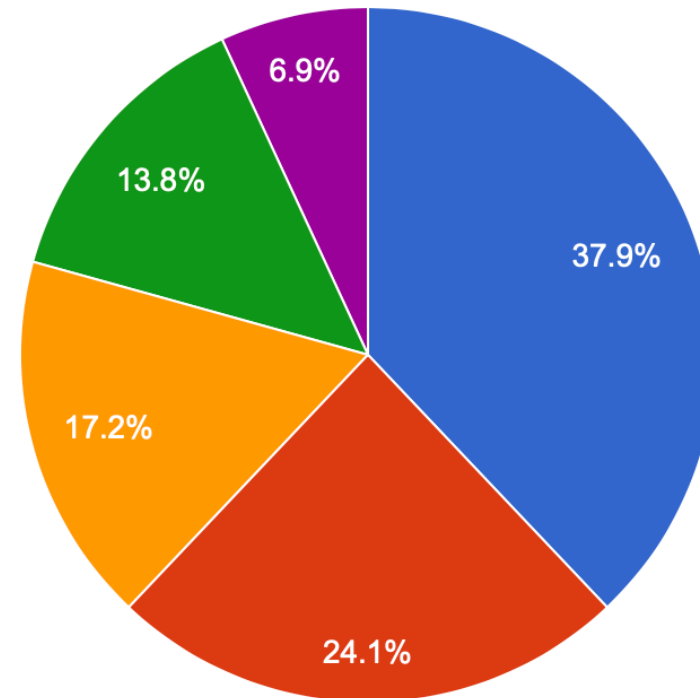

# MarCaS Program

## Keynote

### *A Ship Honeynet to Gather Cyber Threat Intelligence for the Maritime Sector*

Jeroen Pijpker & Stephen McCombie, NHL Stenden University of Applied Sciences, The Netherlands

## Session 1 (10:30-11:50)

## Session 2 (13:00-14:20)

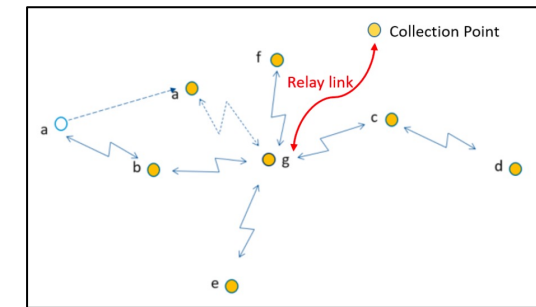
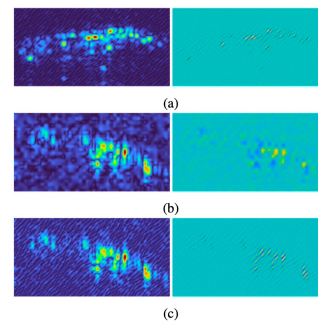
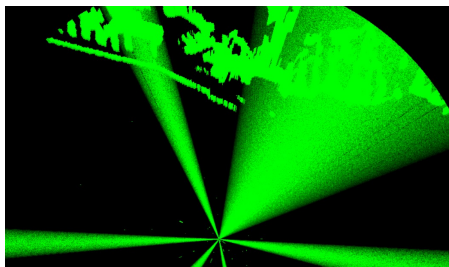

Attack	Public Attack Discovery Date	Attribution Date	Approx. Attribution Time (Years)	Attributing Organizations	Medium of Attribution
DDoS Attacks against US Banks [16]	2013	3/2016	3	US DoJ	Indictment
China - Corporate Espionage [17]	2014	4/2015	1	US DoJ	Indictment
North Korean Spy & SWIFT Hacks [18]	2016	4/2018	2	US DoJ	Indictment
2016 Election Interference [19]	2016	7/2018	2	US DoJ	Indictment
WannaCry [20]	5/2017	3/2021	4	US DoJ	Indictment
WannaCry [21]	5/2017	12/2017	0.5	US NSC	NSA OpEd
NatFryx & 2014 Olympic Attacks [22], [23]	6/2017	10/2020	3	US DoJ	Indictment
2020 Election Interference [24]	2020	3/2021	0.5	US ODNI	Intelligence Assessment Report
Solar Wipers [25], [26]	11/2020	4/2021	0.5	US NSA, CIA, FBI and OCHQ, Microsoft	Joint Statement
World Anti-Doping Agency Attack [27]	2015	10/2019	4	US NSA, CIA, FBI and OCHQ, Microsoft	Microsoft Blog Post, Special Reporter on Executions Report
Hacks in Support of Jamal Khashoggi Murder [28]	10/2018	3/2019	0.5	UN	Special Representative Report
2019 Georgia Attacks [29]-[31]	10/2019	2/2020	1	20 Countries	Statements put out by State/Foreign Affairs Departments
MS Exchange Hack [32], [33]	3/2021	7/2021	0.3	Five Eyes, EU	Statements put out by State/Foreign Affairs Departments

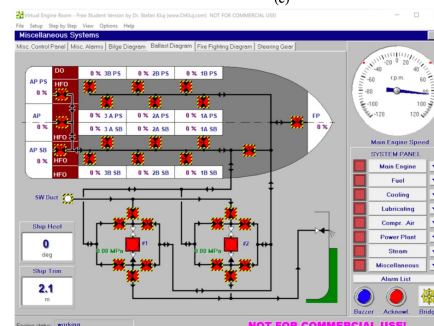

MSSTACK C3 RISC-V ESP32	NODEMCU WIFI CP2102 ESP32	NODEMCU D1 MINI ESP32
Supplier: Bangood CHINA	Supplier: AZDelivery GERMANY	Supplier: AZDelivery GERMANY
N.D. (boot loop)	Consumption test: 130mWh	Est. consumption in ultra-low power mode: 27mWh
NEGATIVE OUTCOME	POSITIVE OUTCOME	POSITIVE OUTCOME

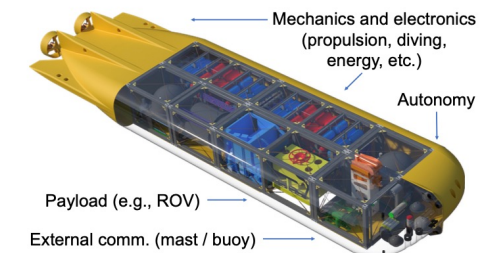

(c) Gary C. Kessler, 2022-2023

# Thank You!



**TPC**

- LCN Conference
  - Technical Program Committee
  - Workshop Authors
  - Audience
- Hosam Alamleh, University of North Carolina Wilmington, USA
  - Rui Bian, USA
  - Udhaya Kumar Dayalan, Trane Technologies, USA
  - Bilge Karabacak, University of North Carolina Wilmington, USA
  - Stephen McCombie, NHL Stenden University, The Netherlands
  - Cliff Neve, MAD Security, USA
  - Aybars Oruc, NTNU, Norway
  - Jeroen Pijpker, NHL Stenden University, The Netherlands
  - Geoff Stoker, University of North Carolina Wilmington, USA
  - Kimberly Tam, University of Plymouth, UK
  - Ron Vetter, University of North Carolina Wilmington, USA
  - Klaus Wehrle, RWTH Aachen University, Germany